



Colour TV Service Manual

Model Group: CT-21TF9

CHASSIS: 3Y01

MODEL:

CT-21TF9A

CT-21TF9C

CT-21TF9CP

CT-21TF9CP(IKD)

CT-21TF9CP(SKD)

CT-21TF9CP(M)

CT-21TF9N

CT-21TF9R

CONTENTS

Specifications	4
X-Ray Radiation Precaution	5
Safety Precaution	5
Product Safety Notice	5
Alignment Instructions	6
Schematic Diagram	14

SPECIFICATIONS

RECEIVING SYSTEM

Sound System	: A = BG/DK/I/M, R, N = BG/DK/I, CP = BG
Colour System	: A = PAL/SECAM/NTSC/NTSC P/B R, N = PAL/SECAM/NTSC P/B CP = PAL/NTSC P/B
Picture Tube	: 54 cm (21") diagonal
Ext. Antenna	: 75 Ohm Coaxial Cable
Ext. In/Out	: Audio/Video-in/out
Speakers	: 5W x 2
Volts	: A = AC 100 ~ 260V 50/60Hz R,N,CP = AC 150 ~260V 50/60Hz
Power Consumption	: 21" = 80W
Dimension	: 21" = 610(W) x 482(D) x 455(H) mm
Net Weigh	: 21" (24kg)

REMOTE CONTROL

Transmitting System	: Infra-red
Power Supply	: DC 3V (1.5Vx2)

Design and specifications are subject to change without prior notice

CAUTION

Before servicing the chassis, read the “X-Ray Radiation Precaution”, “Safety Precaution” and “Product Safety Notice” on this page.

X-RAY RADIATION PRECAUTION

1. Excessive high voltage can produce potentially hazardous X-Ray Radiation. To avoid such hazards, the high voltage must not be above the specified limit. The normal value of the high voltage of this receiver is 24KV at zero beam current (minimum brightness) under 220V AC power source. The high voltage must not, under any circumstances, exceed 30KV.
2. Each time a receiver requires servicing, the high voltage should be checked following the High Voltage Check procedure in this manual. It is recommended the reading of the high voltage should be recorded as a part of the service record. It is important to use an accurate and reliable high voltage meter.
3. The primary source of X-Ray Radiation in this TV receiver is the picture tube. For continued X-Ray Radiation protection, the replacement tube must be exactly the same type tube as specified in the part list.
4. Some parts in this receiver have special safety – related characteristics for X-Ray Radiation protection. For continued safety, parts replacement should be undertaken only after referring to the Product Safety Notice.

SAFETY PRECAUTION

Warning: Service should not be attempted by anyone unfamiliar with necessary precaution on this receiver. The following are the necessary precautions observed before servicing this chassis.

1. Since the power supply circuit of this receiver is directly connected to the AC power line, an isolation transformer should be used during any dynamic service to avoid possible shock hazard.
2. Always discharge the picture tube anode to the CRT conductive coating before handling the picture tube. The picture tube is highly evacuated and if broken, glass fragment will be violently expelled. Use shatter proof goggles and keep picture tube away from the unprotected body while handling.
3. When replacing a chassis in the cabinet, always be certain that all the protective devices are put back in place, such as: non-metallic control knobs, insulating covers, shields, isolation resistor-capacitor network etc.
4. When replacing parts or circuit boards, disconnect the power cord.
5. When replacing a high voltage resistor (Metal oxide film resistor) on circuit board, keep the resistor 10mm (1/2in.)away from circuit board.
6. Connection wires must be kept away from components with high voltage or high temperature.
7. If any fuse in this TV receiver is blow, replace it with the FUSE specified in the chassis part list.
8. The receiver is designed to operate with 220V(50/60Hz) AC mains.

PRODUCT SAFETY NOTICE

Many electrical and mechanical parts in this chassis have special safety –related characteristics. These characteristics are often passed unnoticed by a visual inspection and the X-Ray Radiation protection afforded by them cannot necessarily be obtained by using replacement components rated for high wattage, etc. Replaced parts which have these special safety characteristics are identified in this manual and its supplements, electrical components having such features are shaded on the schematic diagram and the part list.

Before replacing any of these components, read the part list in this manual carefully. The use of substitute replacement parts, which do not have the same safety characteristics, as specified in the part list may create shock, fire, and X-Ray Radiation or other hazards.

ALIGNMENT INSTRUCTION (3Y01)

GENERAL SET-UP

1. Please notice the following before alignment and equipment:
 - 1.1. Don't short any two soldering points, which should not be shorted and don't touch any components, which should not be touched.
 - 1.2. Please pull out plug before equipment.
 - 1.3. For safety reasons, all components equipped or replaced should be identical with BOM.
 - 1.4. Must be warm up for 30 minutes or more and degauss CRT thoroughly with demagnetizer before alignment.
 - 1.5. The data of EEPROM must be stored before the adjustment for main chassis.

2. Tools and equipment for adjustment
 - 2.1. Small "-" screwdriver
 - 2.2. Screwdriver without inductance
 - 2.3. Pattern Generator
 - 2.4. DC Regulated power supply
 - 2.5. Digital Voltmeter
 - 2.6. Sweep Signal Generator
 - 2.7. 20MHz 2-channel Oscilloscope

3. Signal condition

ITEMS	LOGO	PICTURE CARRIER	PATTERN	SYSTEM	SOUND MODE	REMARK
1	CHN-1CH	49.75MHz	PHILIPS PATTERN	PAL-I	1KHz	
2	WE-6CH	182.25MHz	RED PATTERN	PAL-B/G	L: ----- R:400Hz	STEREO/ TELETEXT
3	CHN-12CH	216.25MHz	GREY SCALE /COLOR BAR	SECAM-D/ K	SWEEP SOUND	
4	CHN-13CH	471.25MHz	CROSS HATCH PATTERN	PAL-D/K	1KHz	
5	USA-33CH	585.25MHz	COLOR BAR	NTSC-M	-----	WITHOUT SOUND CARRIER
6	-----	751.25MHz	MONOSCOPE PATTERN	PAL-I	SWEEP SOUND	
7	-----	85.25MHz	GREY SCALE /COLOR BAR	SECAM-L'	1KHz	SYS-2
8	WE-S20CH	294.25MHz	Semi-COLOR BAR	PAL-B/G	A:400Hz B:1KHz	DOUBLE SOUND CARRIER

(A) MAIN CHASSIS ALIGNMENT

1. IF ALIGNMENT FOR MAIN CHASSIS

- 1.1. PIF Adjustment (38.9MHz)
- 1.2. Tuner AGC connects to GND. Pattern Generator outputs 38.9MHz R.F. signal and connects to tuner output terminal or pin5 of saw filter.
- 1.3. Connect Digital voltmeter across C227. DC Regulated power supply positive terminal output +20V to pin1of IC203 and negative terminal of D608. DC Regulated power supply negative terminal connects to pin2 of IC203.
- 1.4. Adjust L203 coil to obtain 3.6V Digital voltage meter reading.

Fig.1

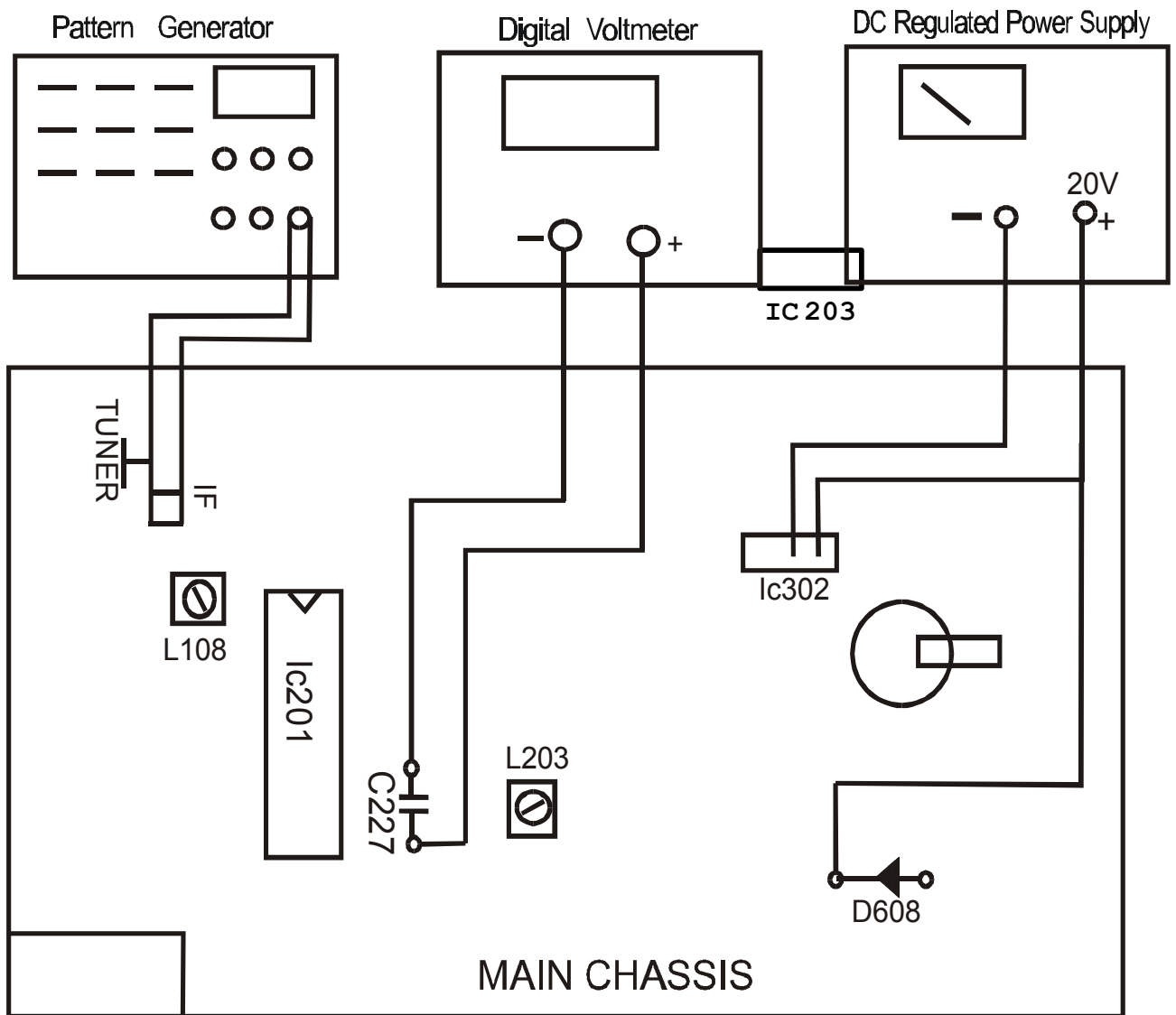

2. SYSTEM NTSC ADJUST (L108).

- 2.1. Tuner AGC connects to GND. Connect Sweep Signal Generator to tuner IF output terminal oscilloscope V-IN terminal connects to C109. And connect Q102 'base' pole to the power terminal(+9V) of R104 through a 10KΩ resistor.(shown in FIG.2)
- 2.2. Apply +20V DC across IC302 as shown in FIG.2.
- 2.3. Adjust L108 to obtain waveform as following.

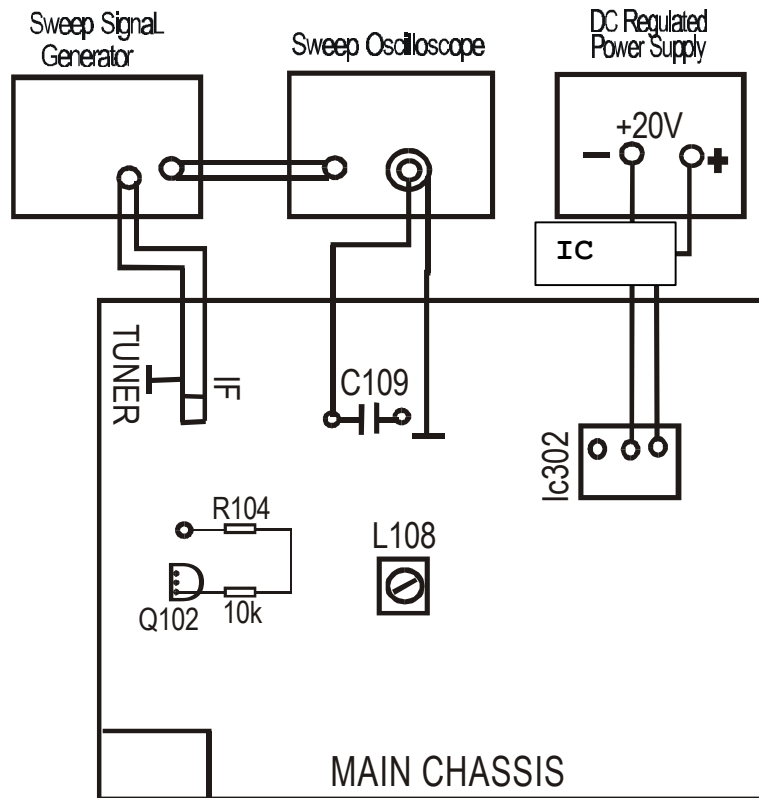
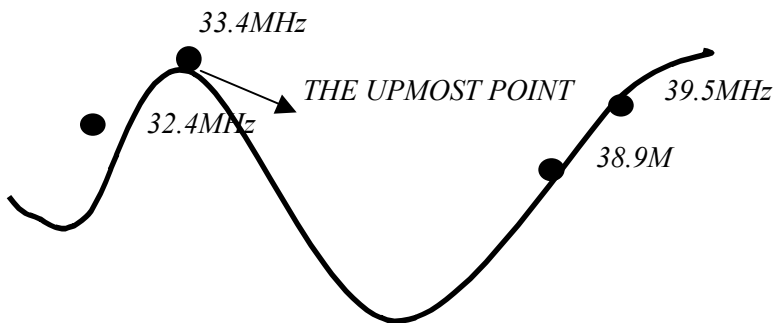

FIG.2

Note: There will be no alignment required for TV without off-air NTSC system feature.



3. B+ ADJUSTMENT

- 3.1. Disconnect horizontal load. Connect a light bulb (100 W) AC 250V across C321.
- 3.2. Connect 220V AC 50Hz to CN601 and switch on power switch.
- 3.3. Test the voltage with digital voltage meter between C321 two terminals.
- 3.4. Adjust VR601 to obtain +110V +/- 0.5V.

4. AGC ALIGNMENT

- 4.1. Receive 60dB +/- 2dB RF signal. Connect Digital voltmeter positive terminal to AGC terminal of TUNER and negative terminal to GND.
- 4.2. Press "MENU" key twin, till the PICTURE MENU appears, then press "Q.VIEW" or "RETURN" key, "MUTE" key to turn on CPU. TV SET will go to factory mode. Press "TIMER" key to go to the next factory menu. Go to "MENU 3" status by this means.
- 4.3. Select RF.AGC by pressing "CH+" or "PROG+" and "CH-" or "PROG-" keys. Adjust "VOL+" and "VOL-" keys to obtain 4V Digital voltage meter reading.
- 4.4. Press "MENU" key to exit factory mode.

(B) CTV SET ALIGNMENT**1. GO TO FACTORY MODE ACCORDING TO 4-4-2 BEFORE WARM UP LINE.****2. FOCUS ADJUSTMENT.**

- 2.4. Receive monoscope pattern.
- 2.5. Set TV to work in dynamic status.
- 2.6. Adjust the focus knob of FBT to get the clearest picture.

3. SCREEN VOLTAGE ADJUSTMENT.

Go to factory mode "MENU 2" status according to 4-4-2.

- 3.4. Select "V-KILL" by pressing "CH+" or "PROG+" and "CH-" or "PROG-" keys..
- 3.5. Press and hold on the "VOL+" key all the time, Adjust the screen knob of FBT to get a horizontal faintness beam line. Then release "VOL+" key.

4. (A) WHITE BALANCE ADJUSTMENT (APPLIED IN FACTORY ONLY)

- 4.1. Set the TV set to AV mode. Receive black white pattern (Color Temperature test pattern).
- 4.2. Insert 6 Pin Service flat cable into CN002. Press adjustment keys, and then go to automatic white balance adjustment.
- 4.3. After adjusting well, remove the 6 Pin Service flat cable.

(B) WHITE BALANCE ADJUSTMENT (APPLIED WHEN SERVICING)

- 4.4. Set the TV set to AV mode. Receive black white pattern (Color Temperature test pattern).
- 4.5. Put the test probe 1 of CRT color analyzer (CA-100) on the Low Bright area and the test probe 2 on the High Bright area. Adjust bright and contrast to get 5nit of low bright area and 80 nit of high bright area.

- 4.6. Go to factory mode "MENU2" according to 4-4-2. Obtain Low Bright area to $x=281$ and $y=311$ by adjusting R.bias and B.bias. Obtain High Bright area to $x=281$ and $y=311$ by adjusting R.drive and B.drive. Obtain both area to $x=281$ and $y=311$ by adjusting the two status repeatedly.

5. SUB-BRIGHT ADJUSTMENT

Receive GREY SCALE signal. (PHILIPS PM54200, 11 STEP)

- 5.1. Set TV at normal mode.
- 5.2. Get into factory mode, adjust sub-bright option to make the picture same as below.

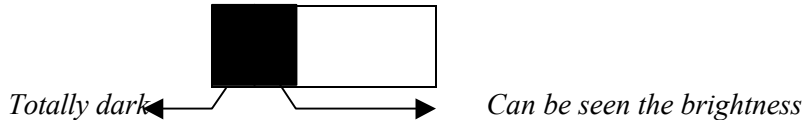

6. VERTICAL SIZE AND PINCUSHION ADJUSTMENT.

- 6.1. Receive monoscope pattern. Set TV standard status. Adjust V.size to obtain picture's vertical redisplay ratio more than 90% in factory mode "MENU1".
- 6.2. Receive cross hatch pattern. Set TV standard status. Adjust V.LINE and V.SC to obtain picture's vertical pin cushion a good status in factory mode "MENU1".
- 6.3. Receive cross hatch pattern. Set TV standard status. In factory mode "MENU1" adjust V.POSITION to obtain picture's vertical center at the center of CRT screen.

7. HORIZONTAL CENTERING ADJUSTMENT.

- 7.1. Receive PHILIPS PATTERN. Set TV standard status. Adjust H.PHASE to obtain horizontal center at the center of CRT screen.

8. SECAM COLOR DECODER ALIGNMENT.

- 8.1. Receive the GREY SCALE /COLOR BAR signals. Enter into the factory mode. Adjust the values of Secam R-Y DC and Secam B-Y DC to make the gray scale to the normal color.

9. COLOR PURITY ADJUSTMENT

- 9.1. Before color purity adjustment, Warm up the TV set over 15 minutes and fully degauss.
- 9.2. Receive pure white signal in AV status and set the TV receiver dynamic.
- 9.3. Go to factory mode "MENU2". After write down the values of R-BIAS and B-BIAS, set the values of R-BIAS and B-BIAS zero.
- 9.4. Loosen the clamp screw of the deflection yoke and pull the deflection yoke towards color purity magnetic loop.
- 9.5. Adjust color purity magnetic loop to make the green area at the center of CRT screen.
- 9.6. Slowly push the deflection yoke toward the front of CRT and set it where a uniform green field is obtained. Tighten the clamp screw of the deflection yoke.
- 9.7. Restore the values of R-BIAS, G-BIAS and B-BIAS

10. CONVERGENCE ADJUSTMENT

- 10.1. Receive a dotted pattern. Set the TV receiver dynamic.
- 10.2. Loosen the convergence magnet clumper and align red with blue dots at the center of the screen by rotating (R, B) static convergence magnets.
- 10.3. Align Red/Blue with green dots at the center of the screen by rotating (RB-G) static convergence magnet.
- 10.4. Remove the DY wedges and slightly tilt the deflection yoke horizontally and vertically to obtain the good overall convergence. Fix them after the good overall convergence is obtained.
- 10.5. Fix the convergence magnets by turning the clumper.
- 10.6. If purity error is found, follow "PURITY ADJUSTMENT" instructions.

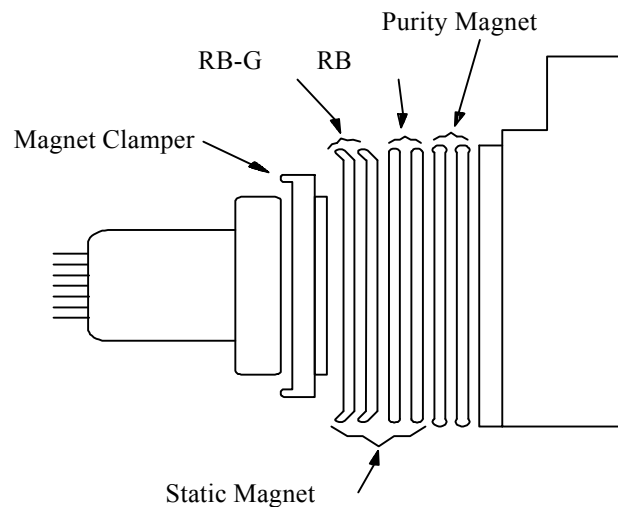
**(C) FINAL INSPECTION AND ELECTRICAL FUNCTIONAL CHECK****1. CHECKING THE ELECTRICAL FUNCTION:-**

- 1.1. Connect the power cord and connect the signal to RF input.
- 1.2. Check the power supply whether OK or not. Switch on the TV set and the LED is on. Switch off the TV screen and should not have CRT spot within 3 sec.
- 1.3. Receive the channel 1 for monoscope pattern to check the picture focus and the round circle should not be distorted. The centre position, and VOS line/size are within spec. Check the brightness, contrast and colour condition. Check the convergence, picture must be clear, focus OK and white balance are OK. Also check the complete screen picture quality. High voltage condition OK and the Screen picture must be OK.
- 1.4. Check all the functional keys must be working well.
- 1.5. Receive colour pattern signal and the system colour. (PAL/SECAM/NTSC). Check the power main on/off switch, brightness, volume, colour, contrast and tint. The picture quality must not have colour noise, unbalance size and distorted condition.
- 1.6. Check the sound quality standards, Volume up/down are OK to spec, and sound output. Ensure the sound output is not distorted and noisy. No interference for DK/BG/I/M.

- 1.7. Use remote Control Unit for all types of function check and ensure OK.
- 1.8. Check the words display condition.
- 1.9. Shock test and make sure the picture and sound are not distorted and shifted.
- 1.10. Use strong and weak signal to check the colour picture condition. After adjust the signal level to 35-40 dB and the colour should not gone. The picture and sound must be OK. At 60 dB the picture should not have snow noise.
- 1.11. Ensure the factory mode setting are set. Set-off the factory mode function and last switch off the TV set.
- 1.12. All the “NG” sets must send for repairing and recording for reference.
- 1.13. Check the AV input and output the picture and sound must be OK.

2. RELIABILITY AGING TEST:-

- 2.1. 1st lot of production sets. Sampling 20 sets for aging 7 days continues test with colour signal in. Normal production sets must be age for 1 day.

3. MECHANICAL INSPECTION:-

- 3.1. Inspect all glue are firmly placed.
- 3.2. Check all screws are tightened, no missing and loose.
- 3.3. Check all the connectors are fully located onto the chassis base.
- 3.4. Check all the safety components are firmly located onto the chassis and no damage.
- 3.5. The TV internal side should not see any excess metal materials.
- 3.6. Check all the cable and wire are OK in-used.
- 3.7. Check the FBT and switching transformers not high mounting. The big capacitor are not slanting and high mounting.

4. HIGH POTENTIAL TESTING:-

- 4.1. Set the mega-meter is set in position.(Insulation tester)
- 4.2. Set the meter to DC500V.
- 4.3. Use the meter probe onto the tuner body and the power cord on connector socket.
- 4.4. Switch on the button and test the insulation performance and the reading at 2/3 position.
- 4.5. Insulation spec must over 9.0 Mohm. if not reject.
- 4.6. Note: Everyday work check the high pot. Condition as 3100V, 10 mA, 5 sec are OK.

5. SAFETY CHECK:-

- 5.1 High voltage checking. Use high pot tester and set the tester to 3100V, 10mA and ensure the AC/DC switch is in AC position. Set the tester to 10mA and timer to 5 sec. Test all naked metal of the TV and ensure no arcing and sparking.
- 5.2 Checking methods.
 - 5.2.1. connect the power cord into power socket.
 - 5.2.2. the high pot tester gun pointed at metal part of TV set body.
 - 5.2.3. switch on the switch to test the high electric power.
 - 5.2.4. connect with high voltage within 5 second and remove the tester gun point.

Appendix: If customer logo is needed, please set LOGO ON 1 and CUS.LOGO (or CUSTOM LOGO) 1 at the SERVICE MODE. Change the data of E²prom to get the custom logo with special implement (I2C converter Board and Computer). Please see the details as following.

Method to Write Data for Custom Logo

The are total 12 characters that can be input into E²prom and display on the TV. The address range of E²prom (24C04) is from 170H-17BH. The following table shows the code input character.

Character	Data Code	Character	Data Code
'0'	30H	'K'	4BH
'1'	31H	'L'	4CH
'2'	32H	'M'	4DH
'3'	33H	'N'	4EH
'4'	34H	'O'	4FH
'5'	35H	'P'	50H
'6'	36H	'Q'	51H
'7'	37H	'R'	52H
'8'	38H	'S'	53H
'9'	39H	'T'	54H
'A'	41H	'U'	55H
'B'	42H	'V'	56H
'C'	43H	'W'	57H
'D'	44H	'X'	58H
'E'	45H	'Y'	59H
'F'	46H	'Z'	5AH
'G'	47H	'/'	2FH
'H'	48H	'.'	2EH
'I'	49H	'*'	40H
'J'	4AH	' '	09H

Chassis 3Y01 (150V ~ 260V)

